



NCAT Report 05-01

# **DEVELOPMENT OF RAPID QC PROCEDURES FOR EVALUATION OF HMA PROPERTIES DURING PRODUCTION**

**By**

**Randy C. West**

**January 2005**



277 Technology Parkway Auburn, AL 36830

**DEVELOPMENT OF RAPID QC PROCEDURES FOR  
EVALUATION OF HMA PROPERTIES DURING PRODUCTION**

By:

Randy C. West  
Assistant Director  
National Center for Asphalt Technology  
Auburn University, Auburn, Alabama

Sponsored by

The Federal Highway Administration

NCAT Report 05-01

January 2005

## **DISCLAIMER**

The contents of this report reflect the views of the author who is responsible for the facts and accuracy of the data presented herein. The contents do not necessarily reflect the official views or policies of the National Center for Asphalt Technology or Auburn University. This report does not constitute a standard, specification or regulation.

## TABLE OF CONTENTS

INTRODUCTION .....	1
Background.....	1
Purpose and Scope .....	1
Methodology .....	2
PLAUSIBLE TECHNOLOGIES FOR REAL TIME TESTING.....	3
Automated Belt Sampling.....	3
Automated Moisture Content of Aggregates and RAP.....	4
Automated Gradation of Virgin Aggregates.....	4
Automated Viscosity of Asphalt Binder .....	5
Automated Calibration of Asphalt Meters.....	6
Automated Data Management .....	7
Robotic Truck Sampler.....	8
OTHER PLAUSIBLE TECHNOLOGIES FOR HMA PRODUCTION .....	8
Video Imaging of Gradation and Particle Shape Analysis .....	8
Ferromagnetic Tagging.....	9
DISCUSSION OF AUTOMATION TECHNOLOGIES .....	9
Panel Discussion: Questions and Responses .....	9
Cost/Benefit of QC Automation Technologies.....	14
STRATEGIC PLANNING .....	15
Process Framework.....	15
Funding for QC Automation Technology Development .....	17
CONCLUSIONS & RECOMMENDATIONS.....	18
REFERENCES .....	19
APPENDIX A.....	20
APPENDIX B.....	22

## ABSTRACT

Current processes for quality control of Hot Mix Asphalt (HMA) are inefficient and place considerable risks on HMA producers and transportation agencies. This project was established to explore possible new ways of gathering real-time quality control information. The two primary goals of real-time testing are: to dramatically shrink the time lag for quality control information, and to improve the reliability of the data. To meet the objectives of this study, a panel of individuals familiar with current and or new QC technologies was assembled to discuss concepts, brainstorm possibilities, and map out a general strategy for evaluation of new methods and technologies.

Based on this meeting, the most promising concept for real-time testing appears to be the utilization of automation technologies to check the consistency of the materials feeding into an HMA plant. Specific automation technologies that appear most promising include:

- Continuous, in-line viscosity of the asphalt binder. The viscosity of the binder should provide an indication that the appropriate grade of binder is being used in the mix.
- Automated belt sampling of the virgin aggregate from the conveyor before it enters the dryer. An automated sample dryer and gradation device integrated with belt sampler should provide rapid feedback of the consistency of the aggregate.
- For continuous mix plants, asphalt contents of HMA mixtures can be monitored with the readings from the plant's asphalt meter and belt scales. Calibration of the components used to determine real-time asphalt content is a key to the reliability of this data.
- The automated technologies should be integrated as a system with programmable controls, data acquisition, and report generation.

At the present time, there do not appear to be any technologies that can be used to automatically determine the composition of RAP or to test important characteristics of the produced mixtures such as volumetric or other performance-related properties. It is strongly recommended that automated methods for characterizing these materials be researched. A national oversight group specific to exploring real-time testing of HMA is also recommended.

## **DEVELOPMENT OF RAPID QC PROCEDURES FOR EVALUATION OF HMA PROPERTIES DURING PRODUCTION**

Randy C. West

### **INTRODUCTION**

#### **Background**

Current quality control methods for Hot Mix Asphalt (HMA) are manpower and time intensive which leads to inefficient gathering of information needed to monitor and control the production of quality asphalt mixtures. The majority of attention in QC testing is now spent on sampling and testing after the mixtures are produced. Considering that it typically takes about three hours to complete the suite of tests commonly used for QC of asphalt mixtures, and that the majority of plants commonly produce HMA at rates of 200 to 300 tons per hour, then it is common for 600 to 900 tons of HMA to be produced between tests. This lag of information puts the HMA producer at significant financial risk and the customer (i.e. agency) at risk of accepting a significant amount of poor quality materials.

In addition to the risks associated with the QC information time lag, it is recognized by the collective HMA industry that most of the tests used in QC and acceptance testing suffer from poor precision. Part of the poor precision is attributable to sampling and testing variability which are related to the skill and ability of technicians. The effect of this poor precision is that it confounds decision making. If uncertain about a test result, technicians or managers will often resample and test to validate the first result. This further extends the information lag and increases the risks. However, if the technician or manager incorrectly reacts to bad data, then the mixture may be adjusted when it should not have been. More effective techniques are needed to assure that quality HMA is being produced.

#### **Purpose and Scope**

This project was established to explore possible new ways of gathering real-time quality control information. If the concept of real-time QC appears feasible, a strategy for the evaluation of new methods and technologies should be developed.

The two primary goals of real-time testing are: to dramatically shrink the time lag for quality control information, and to improve the reliability of the data (i.e. significantly reduce sampling and testing variability). Ultimately, these improvements should reduce the risks to producers and customers and lead to better pavement performance by providing better quality control.

Real-time testing is envisioned to be different from current QC practices in two ways. First, real-time testing will involve automating the processes for obtaining information. This includes automation of sampling, testing, calculations, and data management. By removing human technicians from the processes, it is expected that overall testing variability will be reduced and potential bias will be eliminated. The second key difference of real-time testing is the point in the

production process where samples are taken. Real-time testing will shift the focus of gathering information back to assessing if the raw materials going into the mix are correct and consistent.

Over the past decade, attention has been given to improving the laboratory tests used for quality control of HMA. Many of the improvements have centered on making the tests faster and less variable. For example, the NCAT ignition furnace test developed about 10 years ago, has provided a faster and more reliable method of determining asphalt content of plant produced mixtures. Faster and better lab procedures, although a worthwhile pursuit, provide only incremental improvements to quality control. As it is envisioned, real-time automated testing is a quantum leap ahead in quality control. Real-time testing will involve automated feedback during the mix production process and construction operations. Automated testing is envisioned to mean that information is obtained without direct human interaction.

The objectives of this report are to:

1. Present plausible technologies that may be developed to provide real-time, automated quality control information regarding HMA production and construction,
2. To identify possible technological and social hurdles that may be encountered with the development and/or implementation of those technologies,
3. To provide a process framework for the development, evaluation, and implementation of automation technologies.

## **Methodology**

To meet the objectives of this study, a panel of individuals familiar with current and or new QC technologies was assembled to discuss concepts, brainstorm possibilities, and map out a general strategy for evaluation of new methods and technologies. The roster for the panel and the agenda for the meeting are included in Appendix A.

This panel meeting was held immediately following an open house where several new devices for automated QC testing at a new HMA plant were demonstrated. This QC Automation Open House highlighted the following methods for sampling and testing of materials during the production of HMA.

1. Automated Belt Sampling of Aggregate and RAP
2. Automated Moisture Contents of Aggregate and RAP Using Moisture Probes and Sample Drying Units
3. Automated Gradation of Virgin Aggregates
4. Automated Viscosity of Asphalt Binders
5. Automated Calibration of Asphalt Meters
6. Automated Measurement of Mix Temperature
7. Automated Data Collection and Management

These devices have been installed on East Alabama Paving Company's plant in Opelika, AL and are being evaluated as part of a current project sponsored by the Alabama Department of Transportation. NCAT is conducting the evaluation. The final report for this project is expected to be completed in early 2005.

## PLAUSIBLE TECHNOLOGIES FOR REAL TIME TESTING

This section describes the automated devices that are being evaluated in the on-going project sponsored by the Alabama Department of Transportation.

### Automated Belt Sampling

Automated belt samplers (Figure 1) are used to obtain a sample of the material on a moving conveyor belt. When a belt sampler is activated, an open box rapidly sweeps transverse across the belt closely following the contour of the belt so that all of the material in the cross-section is removed. The speed of the sweep is very fast to obtain an even cross-section of material and minimize the potential influence on belt scales. Belt samplers have been used by other industries, particularly the mining industry, for several decades, so this technology is mature and the equipment is robust enough for the HMA industry. The sample obtained by the belt sampler can be deposited into a bucket or go straight into another automated device such as a drying unit or gradation unit. The size (mass) of the sample will depend on the amount of material on the belt and the size (width) of the box. A typical sample mass obtained by an automated belt sampler will be between 30 to 40 pounds for the HMA industry. Belt samplers can be placed on virgin aggregate conveyors and/or RAP conveyors. Automated belt samplers are manufactured by several companies and their costs range from \$10,000 to \$15,000 installed. Some conveyors may require additional support or frame modification.



**Figure 1. Automatic Belt Sampler**



## **Automated Moisture Content of Aggregates and RAP**

The moisture content of the materials on the belt are needed to correct the mass measurement (e.g. tons/hour) of the conveyor belt scales. There are two techniques that are being evaluated on the project to determine moisture contents. The first technique utilizes probes that can be inserted into the stream of material traveling on the belt (Figure 2). These probes are based on a microwave technology which instantaneously senses the microwave energy absorbed by the material. The energy absorbed is proportional to the moisture content of that material. This technology has been used in several other manufacturing applications, including the ready-mix concrete industry. For this project, moisture probes are installed on the virgin aggregate conveyor belt and the RAP belt.

The second method for determining moisture content in this study is with automated sample dryers which receive materials from the automated belt samplers. The dryers used on this project are first production units. These dryers (Figure 3) use electric heating elements to heat the sample to a temperature around 325 F until the sample reaches a constant mass. The drying units are suspended on load cells so that the sample mass can be monitored by a programmable logic controller (PLC) and the moisture content of the sample is automatically calculated. Drying times for a 30 to 40 pound sample are in the range of 30 to 40 minutes.



**Figure 2. Microwave Moisture Probe**



**Figure 3. Automated Sample Drying Device**

## **Automated Gradation of Virgin Aggregate**

After the aggregate sample is dried by the automated drying unit, it is then directed into an automatic gradation device (Figure 4). The gradation device is similar to laboratory sieving equipment. It is equipped with seven standard sieve screens (12.5 mm, 9.5 mm, 4.75 mm, 2.36 mm, 1.18 mm, 0.3 mm, and 0.075 mm). Other sieve screens can be used. The shaking of the screens is accomplished with variable frequency vibrators. After shaking for a programmed

interval, the unit is rotated 90 degrees and each screen is emptied one at a time into a catch pan. The catch pan is suspended on three small load cells connected to a PLC which calculates the gradation as percent passing each sieve. The gradation unit used on this project is one of the first built for use at an asphalt plant. A few similar gradation units have been installed on aggregate crushing plants.



**Figure 4. Automated Gradation Device**

### **Automated Viscosity of Asphalt Binders**

An in-line viscometer is installed in the asphalt supply line from the plant's tanks to the point of mixing in the drum (Figure 5). The purpose of the in-line viscometer is to indicate if the correct binder grade (e.g. PG 64-22 or a PG 76-22 binder) is being used in the mix. This viscometer uses a magnetically excited vibrating rod in the flow of the fluid (asphalt). The dampening effect of the fluid on the vibrating rod is proportional to the viscosity of the fluid. To compensate for the effect of temperature on the viscosity of asphalt, the instrument also records the temperature of the material and a PLC interface corrects the viscosity to a standard temperature. In-line viscometers are used in a wide range of manufacturing industries.



**Figure 5. In-line Asphalt Viscometer**

### **Automated Calibration of Asphalt Meters**

Continuous-mix asphalt plants use positive displacement pumps or Coriolis type mass flow meters to determine the flow rate of asphalt binder delivered to the point of mixing. These pumps and mass flow meters must be calibrated periodically to assure that the flow rate is accurate for the different binders used at HMA plants. AC calibration tanks provide a reliable, efficient, and safe means for doing this. On this project, a 1000 gallon calibration tank has been plumbed to the plant's asphalt lines (Figure 6). The tank is insulated and is equipped with a hot oil system to maintain temperature. It is supported on three load cells to determine the mass of the tank and asphalt held during the calibration routine. When the calibration procedure is initiated, electronically activated valves divert the asphalt flowing through the flow rate pump into the calibration tank for a specific time interval. The PLC takes the reading of gallons from the pump, converts that volume to mass, and compares that mass to the mass of the asphalt in the tank. If the two mass measurements do not agree, an adjustment factor is applied to the pump reading and the procedure is repeated until the readings agree within a programmed tolerance.



**Figure 6. Asphalt Meter Calibration Tank**

### **Automated Data Management**

A key element of automating testing is programming of the devices and management of the data received from the devices. Programming the devices on the front end deals with triggering of the devices, determining how and what information should be obtained, calibration, and setting of limits. During the test, raw test data from each of the automation devices is sent back to a central data acquisition system located in the plant's control house. The data acquisition system makes associations of data from each source, obtains related plant information, and organizes the information in user-friendly formats such as test reports, tables, and control charts.

Although for this project, the data output will end with the information being retained on the data acquisition PC for future analysis, there are other potential uses of the data collected from the automated tests. For example, it is possible that the gradation information could be used to make adjustments to the cold-feed percentages on the fly. This type of closed-loop automation could be used to provide better control of several parts of mixture production. Other possible outputs of the automated data is to link it to a web-based database so that it could be quickly and easily viewed by other users and/or to establish associations of the test data to physical locations on the pavement through GIS based programs.

## **Robotic Truck Sampler**

Also being evaluated as part of the ALDOT project is a robotic truck sampler (Figure 7) for obtaining a representative sample of HMA from a loaded truck. This machine does require a technician to operate it and so it is not automated like the above devices. However, the robotic truck sampler does obtain a sample from the interior of the load which should be more representative of the load than a sample shoveled from the upper part of the load. The machine also eliminates the need for the technician to get into the back of the truck, which is potentially unsafe. Comparison of results will be made between samples obtained with the robotic truck sampler and the standard practices of shoveling a mix sample from the back of trucks and obtained from behind the paver.



**Figure 7. Robotic Truck Sampler**

## **OTHER PLAUSIBLE TECHNOLOGIES FOR HMA PRODUCTION**

### **Video Imaging of Aggregate for Gradation and Particle Shape Analysis**

Video imaging based technology for automated determination of the particle size and shape distribution of aggregate samples is gaining a foothold in the aggregate industry and it would be a natural progression of the technology to apply it to HMA production. As with the automated gradation unit described above, a sample of the aggregate is removed from the belt using a belt sweeper and drops into the imaging unit. Inside the device, the aggregate sample is fed onto a belt where special cameras and lighting capture 3D images of the particles. Rapid imaging analysis reports particle size distribution and particle shape information. The shape and size data is transmitted wireless or by Ethernet cable to a PC for data storage. At the present, separate units are necessary to capture the range of particle sizes of interest in HMA quality control.

## **Ferromagnetic Tagging**

Ferromagnetic tagging is a technology developed in the automotive industry to verify proper proportioning of two part epoxy resins. This technology works by the addition of a metallic powder into one component of the mixture (tagging). The metallic powder is sensed by electromagnetic equipment to verify the tagged component. The tagged component is mixed with a second component at a target ratio. The mixture is monitored in real-time with another sensor to verify the correct proportions of the two components. This system can be expanded to check the composition of multi-component materials.

This technology has not been applied to HMA manufacturing to date, but the concept of how it may work is illustrated in Figure 9.

## **DISCUSSION OF AUTOMATION TECHNOLOGIES**

Presentations of the above automation technologies were presented at the QC Automation Panel Meeting. The presentations are provided in Appendix B. Following the presentations, the panel was asked a series of questions about the state of technology for real-time testing. This section presents the questions and the panel's responses. The panel members responses were written on cards. Only minor editorial changes were made to the responses for clarity and brevity purposes.

### **Panel Discussion – Questions and Responses**

Question #1: What automated measurements appear to be of greatest value and ready for field trials?

Responses (in order of most frequent to least frequent)

- In-line viscosity of the asphalt binder (11)
- Automated gradation and moisture from belt sampling (10)
- Moisture content on belts / in bins (9)
- Mix temperature measurement and recording (5)
- Binder content (5)
- Improved fines control in plant (2)
- Infrared imaging of post-laydown HMA (2)
- Video grading (1)
- Data management (1)
- Temperature segregation measurement (1)
- Aggregate segregation measurement (1)
- Real-time GPR density measurement (1)
- Asphalt meter calibration (1)
- Automated sampler of HMA (1)
- Temperature at plant, HMA sampler, at delivery, during laydown, during compaction (1)
- Test using aggregate shape characteristics to control mix as opposed to weight (1)
- Measure volume flow of aggregate and volume flow of asphalt to control mix (1)

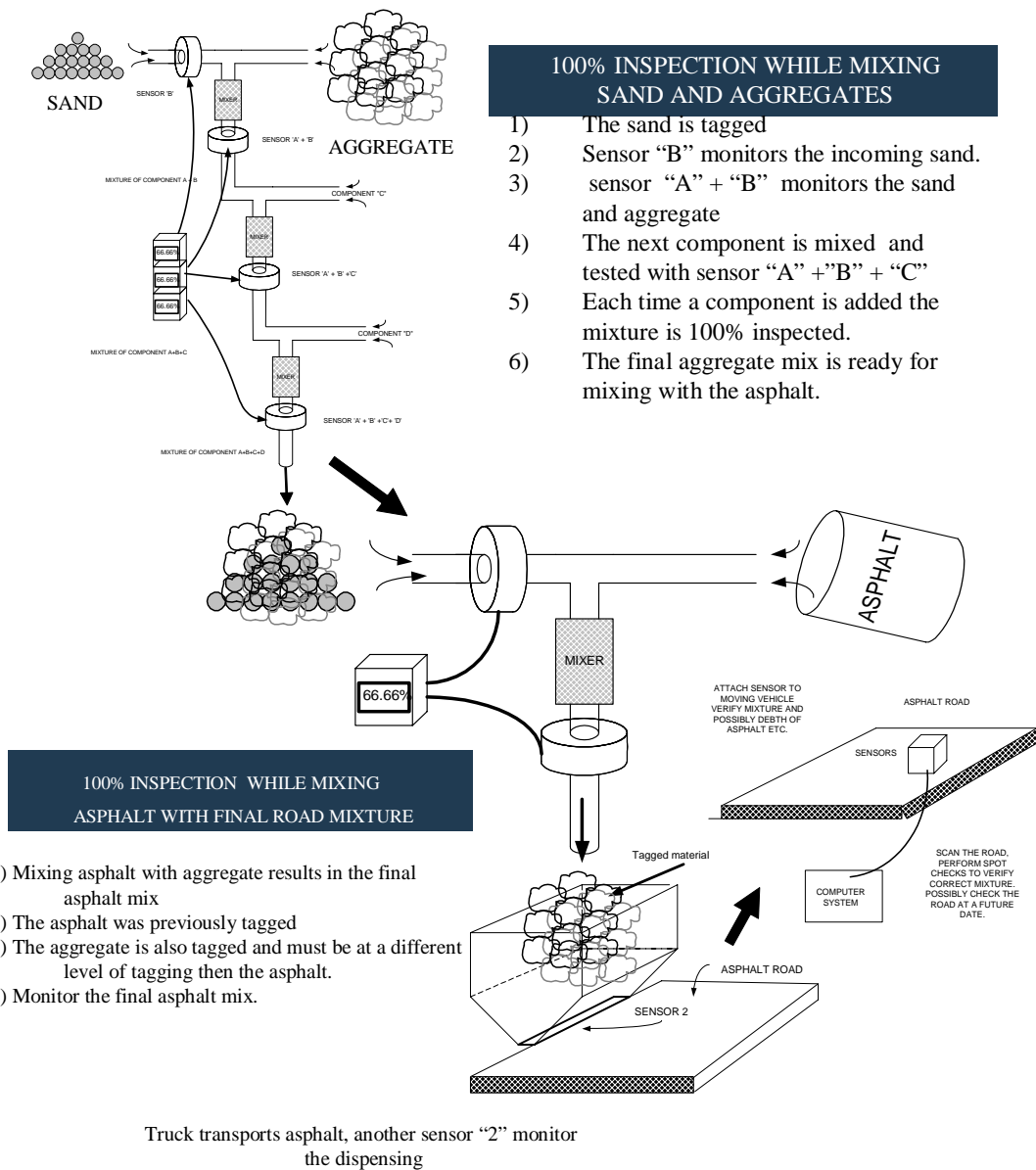

**Figure 9. Concept of Ferromagnetic Tagging in HMA Manufacture**

The panel’s response strongly supports evaluating the feasibility of three technologies: in-line viscosity of the asphalt binder, automatic gradation and moisture content from belt sampling, and the moisture measurement of materials either on the belt or in the cold feed bins. Other technologies which have merit and interest include automating mix temperature measurements and automating binder content determination. Several other ideas/technologies which may provide very useful information to help improve the quality of pavements were also identified.

Question #2: What are possible technical hurdles for the technologies included in the ALDOT project?

1. Automating binder viscosity measurements
  - a. Viscosity is a measure of flow and an indication of molecular weight, but does not measure composition. Composition is important for binder quality because it is a multi-component material. May not be a good indicator for modified asphalt.
  - b. Placement of viscometer to assure proper results.
  - c. Keeping the viscometer in calibration is critical.
2. Automating belt sampling of aggregate and RAP
  - a. Does sample remove fines from the belt?
  - b. Not a washed gradation for belt sampling
  - c. Equipment durability
  - d. Adjustment of samples to insure consistency of sample.
  - e. RAP variability might not be represented by belt sample.
  - f. Ratios of aggregates on cold feed belt are incorrect due to moisture (particularly finer aggregates). Is it ok to measure moisture on blended aggregates rather than in individual basis?
3. Automated gradation of aggregate and RAP by physical sieving?
  - a. Unable to determine gradation of RAP
  - b. Lack of washed gradation is a problem
  - c. Binding, plugging or breaking of screen mesh
  - d. Time to get result is a concern
4. Automated gradation of aggregate and RAP by imaging?
  - a. Need to remove binder from RAP
  - b. Technology is unproven for HMA production
  - c. Imaging only does a limited set of particle sizes
  - d. Moisture and clumping effect
  - e. Need to get to washed gradations
  - f. Cost
  - g. Robustness of the device in this industry
  - h. Maintenance/quality of personnel to keep operating.
  - i. Good for volume control (e.g. SMA), bad for mass control.
5. Automating binder content determination through belt scales and asphalt flow rates?
  - a. Asphalt content of RAP is not automated
  - b. The system does not seem to be working today – Segregation can affect results.
  - c. Calibration of the systems.
6. Automating mix temperature measurements?



- a. Placement of sensors ensuring representative temperature feedback. For thermocouple probes making sure in mix, for Infrared keeping lens clean
  - b. Needs wider sample population (more 3-D)
  - c. Maintenance
  - d. Temperature response/wear issues
  - e. Proper sample location at discharge
  - f. Cost
7. Collecting and managing the automated data?
- a. Need to establish consistent data format (e.g. XML) for different programs
  - b. Need to decide what data is important
  - c. Human motivation to assimilate, interpret the data for efficient use of the results.

This list of possible technical hurdles clearly shows that there are questions and challenges for each of the QC automation technologies. Many of the concerns or uncertainties in these lists will be addressed in the current ALDOT evaluation project.

One of the key missing pieces of information with the automation system in the ALDOT project is the composition of the RAP. There is clearly a need to automate the determination of RAP's asphalt content and gradation in order to confidently estimate the composition of any mixture with RAP as a component. Despite a considerable effort by ASTEC Industries to develop a field ignition tester which could be used to determine the asphalt content of a RAP sample or an HMA mixture sample, a viable method was not established. Further resources should be devoted to finding a solution to this problem.

Question #3: What important information/measurements are missing from the automation system presented above?

- Volumetric Properties of Mix
- Gradation of the Mix
- RAP gradation, asphalt content, and asphalt stiffness
- Aggregate angularity
- Sand equivalent
- Dust (No. 200)
- Performance tests: Rutting, Stripping

The above list shows that the technologies for automated testing included in the ALDOT project is expected to provide only part of what is believed to be necessary to assure quality of an HMA mixture. Most asphalt technologists want to know more than the dry gradation of the virgin aggregate, the viscosity of the binder and the computed percentage of binder in the mix. Volumetric properties (air voids, VMA and VMA) are now considered essential mix characteristics for quality control and quality assurance.

This issue points to a philosophical hurdle that will likely be encountered with the decision of how to use automated QC data. There are several approaches to addressing this issue. The first approach is to consider the information from automated tests as purely supplementary to the

HMA producer's standard quality control. That is, HMA producers would continue to follow their current practices of gathering quality control information by performing laboratory tests at the normal frequency (e.g. 1 test per 1000 tons), and the data from the automated tests would be used as supplementary process control information to aid in making faster and better decisions regarding mix adjustments. A second approach is to allow the data from the automated tests to be used in place of part of the producer's traditional QC testing. For example, the producer would use the automated data to check basic materials compliance to tolerance ranges at a greater frequency (e.g. 1 test per 250 tons), and then verify mixture quality at a reduced frequency (e.g. 1 per 2000 tons) with the traditional laboratory tests such as asphalt content, volumetric properties and gradation of the mixture. For many agencies, this would require a change in specifications that state specific requirements for quality control testing.

Another related issue is how to deal with the use of automated data when the producer's test results are used in the acceptance decisions. If it can be established that the automated data is reliable and the integrity of the information is secure, then some agencies may be comfortable with using some of the automated test data in the acceptance decision.

Question #4: What other technology ideas have you seen or thought of that may be applicable to automated testing of HMA production or construction? .

- Automatic cold bin adjustments based on automated gradation results
- Field "Burn out" oven – for final mix and RAP
- Infrared sensors or cameras behind paver screed to measure temperature segregation
- Smart compactors that monitor mat density on fly
- Ground Penetrating Radar (GPR) to determine mat density
- Automated tests for determining mix volumetrics
- A test for  $G_{sb}$  or  $G_{sa}$  using a Corelock-type device for samples taken from cold feed sweep.
- Automated roadway smoothness using lightweight or high speed profilers
- *HMA View* for guidance on how to correct problems
- Automated sampler for mix behind the paver
- Temperature recording device on the robotic HMA sampler
- Tracing device to follow the mix from batching to laydown
- Double RAP bins to be able to control AC/gradation variations

The responses to this question indicate that there are many other possible technologies that exist in some form, but need further research and development work. Three responses are related to technologies that deal with placement and compaction of HMA: IR sensors for temperature segregation, smart compactors, and GPR. These technologies are promising and are being evaluated in other FHWA research projects. All of the other responses are related to current technologies that are not yet automated.

Question #5: What are possible social, philosophical, or other hurdles that may be encountered with the use of automated technologies?

- Trust of the data
- Maintaining equipment

- Understanding the equipment, why its being used,
- How to use the data
- What will local agencies do?
- Threat to job security for technicians
- Cost of the equipment, return on investment
- Increase in liability due to having data and not acting on it
- Don't tell contractors how to run their business, don't mandate technologies
- Early on, the technology may have to be mandated to get the ball rolling
- No incentive to develop new technologies without pilot projects

This list identifies numerous non-technical issues, some of which may be significantly more challenging than technical limitations. If the technical and economic aspects of automation of QC testing are favorable, there will certainly be logistical and philosophical challenges to getting systems implemented. If the use of automation technologies are also feasible for acceptance determination, other and perhaps greater philosophical changes to the way QA programs are organized and administered will be required.

### **Cost /Benefit of QC Automation Technology**

In addition to the evaluation of technical feasibility of automation technologies, it is also important to consider the economic feasibility of such a system. There are numerous ways to evaluate economic viability of such projects. At this point in time, a definitive economic analysis is not possible due to several unknowns. However, it is important to provide some discussion about the costs and benefits of real-time testing for QC/QA to aid in future analyses.

The first part of a cost/benefit analysis is identification of the costs. Table 1 lists the itemized contract costs, including installation, for the automation equipment for the ALDOT project.

**Table 1. Cost of QC Automation Equipment for the ALDOT Project**

<u>Item Description</u>	<u>Quantity</u>	<u>Unit Cost</u>	<u>Total</u>
Belt Sweepers	2	\$ 14,615	\$ 29,230
Moisture Content Probes	2	\$ 4,180	\$ 8,360
Automated Sample Dryers	2	\$ 13,500	\$ 27,000
Automatic Gradation Unit	1	\$ 37,945	\$ 37,945
In-line Viscometer	1	\$ 22,450	\$ 22,450
Asphalt Calibration Tank	1	\$ 21,130	\$ 21,130
Robotic Truck Sampler	1	\$ 38,000	\$ 38,000
Data Acquisition System	1	\$ 11,000	\$ 11,000
Programming & Training	1	\$ 19,500	\$ 19,500
Bond, Tax, Overhead (10%)			\$ 21,461
<b>Total</b>			<b>\$ 236,076</b>

This may be used as a reasonable estimate of the installed cost for a typical system of automation devices. Such costs may differ for other plant installations and additional or fewer devices may

be found necessary in the future. As a general estimate, annual maintenance and operation costs for the equipment may be approximately 10%. The depreciable life and salvage value for this equipment is unknown at this time.

Estimating the possible financial benefits is a more challenging part of the analysis. Depending on how the automated data is used, the benefits will differ. For example, one benefit may be that higher quality mixtures are produced through better and more timely process control. This would translate to a longer pavement life and a financial benefit to the agency. Better process control may also benefit the HMA producer by achieving higher pay factors on mixtures produced under incentive/disincentive specifications.

A popular method of evaluating the economic benefit of capital investment projects is the payback period. A significant drawback of the payback period analysis is that it does not consider the time value of money. However, it is appropriate for an initial look at the viability of simple projects.

As an example, consider the possible benefit of improved pay for incentive/disincentive contracts resulting from better quality control with QC automation. For an HMA contractor producing 100,000 tons per year for state contracts, with an average in-place price of \$40/ton, it may be possible to increase the average pay factor by two percent for that tonnage of mix. This would yield an additional \$80,000 in revenue. Alternatively, avoiding the cost of removing and replacing 2000 tons of mix would yield the same savings. If the cost of installing the QC automation equipment were \$236,000, the payback period would be less than four years.

## **STRATEGIC PLANNING**

### **Process Framework**

The goal of developing and implementing real-time testing technologies appears worthwhile. The path or paths to reach that goal are likely to be quite complex since automation of quality assurance testing would be a significant change to the industry. What is needed is a general roadmap for how to get there. A process framework is a roadmap that will help identify the necessary steps, provide instructions on how issues may be addressed, possible funding sources, and what parties need to be involved.

A starting point for the incubation or adaptation of new technologies is the TRB's Innovations Deserving Exploratory Analysis (IDEA) program (*1*). The IDEA program goals are to seek out and support new ideas that may benefit the nation's surface transportation system. The program provides start-up funding for promising, but unproven, innovations in four transportation areas: high speed rail, highways, transit, and transportation safety technology. This highway program, known as NCHRP IDEA, is jointly sponsored by the FHWA and AASHTO. Unsolicited proposals may be submitted at any time. A committee of volunteer transportation industry experts reviews proposals twice a year and decides which proposals to consider for funding. Funding support from the NCHRP IDEA program may be up to \$100,000 per project.

Regardless of whether or not new technologies are initially developed using grant funding, a more extensive evaluation program of technologies is necessary. Funding and coordination of these evaluations should be considered at the national level.

To facilitate the evaluation of numerous technologies for quality assurance testing of HMA, the formation of a special automation steering committee would be beneficial. This national oversight group should include participation from FHWA, AASHTO, NCAT and the industry. A conceptual organization structure for the automation steering committee and evaluation teams is shown in Figure 10.

## QC/QA Automation Guidance

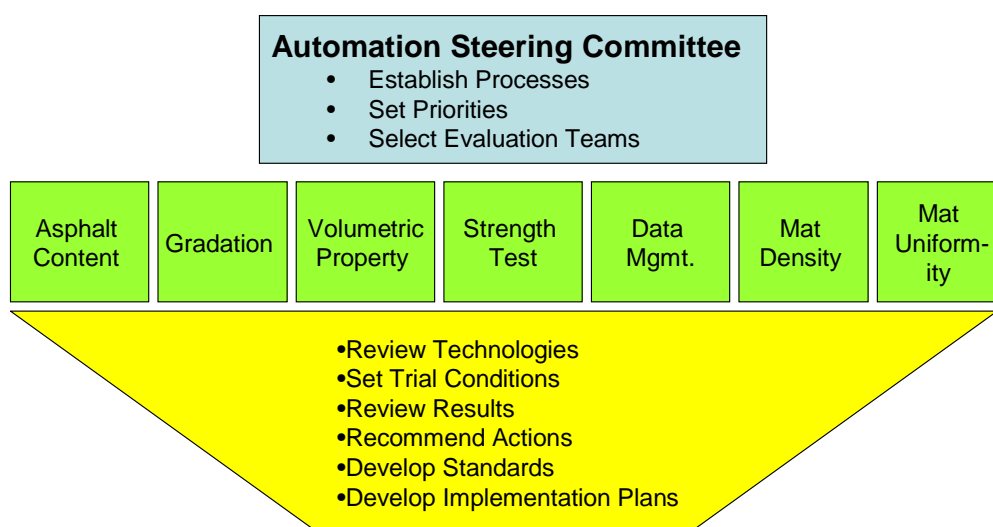

**Figure 10. Possible Organization Structure for QC/QA Automation**

At this time, there is a wide range of pavement and pavement materials related automation technologies in development. This range includes the plant-based automation technologies discussed in this report as well as roadway-based real-time testing technologies such as thermal imaging, intelligent compaction, ground penetrating radar, and high-speed and lightweight profiling. The span of this committee could cover all such automation technologies. Responsibilities of the steering committee may include establishing general guidelines for evaluations, recommending evaluation teams, and setting priorities for what technologies receive support. Evaluation teams would be organized to take responsibility for specific areas of testing. A suggested process framework for automation technology development and evaluation steps is shown in Figure 11.

A summary of key policy issues that a national oversight group should address is listed here:

- Establishing the critical mixture and construction parameters for assuring long-life asphalt pavements.

- Defining the goals of automated testing for HMA quality. Should the information be: used as supplemental QC data, used in lieu of some traditional QC testing, and/or used as part of the material’s acceptance determination? What kinds of checks and balances should be used to verify results?
- Establishing research and development needs and priorities. What technological gaps must be filled? What new technologies should be further evaluated? Identify the funding needs to conduct the prioritized research and development work.
- Establishing the step-by-step processes for the evaluation of quality control automation technologies.

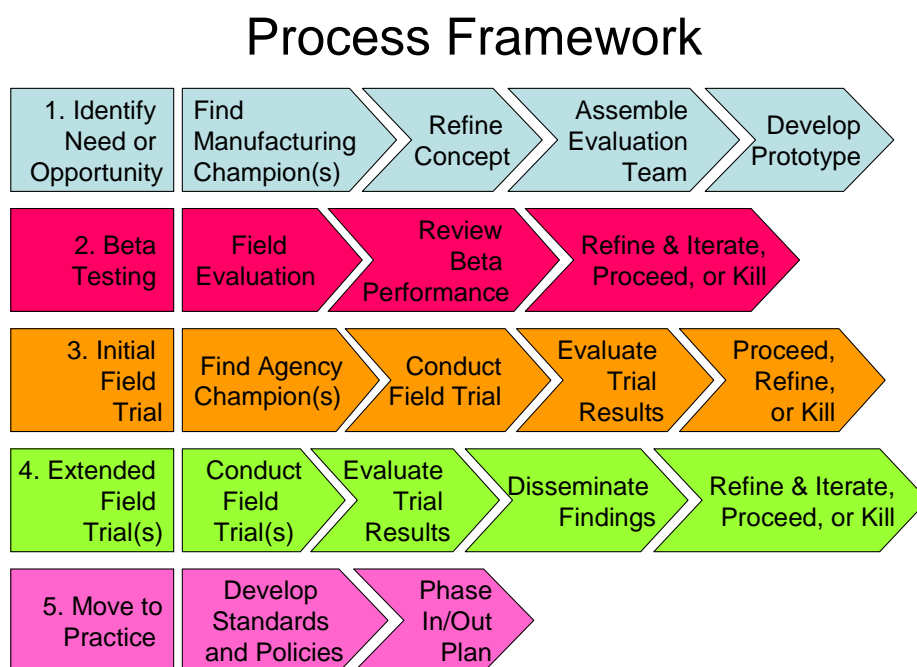

**Figure 11. Process Framework for Evaluating New Automation Technologies**

### Funding for QC Automation Technology Development

Lastly, an important aspect of strategic planning is to consider how development activities related to evaluation of the technologies may be funded. From the ALDOT project, it is clear that considerable funding is needed to evaluate technologies. Each stakeholder should be expected to pay for some part of the development and evaluation of systems. However, since specifications currently drive how quality of materials and construction are evaluated, the momentum to overcome the status quo can be facilitated by government sponsored research to evaluate promising new ideas.

## CONCLUSIONS & RECOMMENDATIONS

The objective of this study was to explore new methods for rapidly evaluating the quality of hot mix asphalt during production. At the present, the most promising concept appears to be the utilization of automation technologies to check the consistency of the materials feeding into the HMA plant. These automation technologies include:

1. Monitoring of the asphalt binder viscosity with an in-line continuous reading viscometer installed in the HMA plant's asphalt supply line. The viscosity of the binder will provide an indication that the appropriate grade of binder is being used in the mix.
2. Automated belt sampling of the aggregate before it enters the dryer. The sample aggregate would then flow into an automated sample dryer and gradation device. This system could be used to obtain faster and more frequent checks of the combined virgin aggregate gradation.
3. For continuous mix plants, asphalt contents of HMA mixtures can be monitored with the plant's existing calibrated asphalt meter and belt scales. To improve the reliability of the readings from the asphalt meter, frequent checks with an integrated asphalt calibration tank should be used. To improve the accuracy of the belt scale readings, moisture content compensation must be automated, and standards for calibration of belt scales and moisture sensors must be established.

The above three technologies should be integrated as an automated system with programmable controls, data acquisition, and report generation. Since these technologies and others are included in a current pilot project sponsored by the Alabama Department of Transportation, the feasibility of this system to provide needed quality control information is being evaluated.

Although the above system is expected to provide rapid feed-back of the consistency of key materials, there are missing measurements that most asphalt technologists feel are necessary to assure the quality of HMA mixtures. In particular, the raw materials information is not complete without determining the composition of RAP used in many mixtures. It is strongly recommended that automated methods for characterizing the composition of RAP be researched. The second critical missing element is a rapid test of the produced mixture. Traditional QC/QA is reliant on mixture volumetric properties as key indicators of mixture performance. Further research is also strongly recommended to develop faster and more automated tests that can provide volumetric analyses or a reliable surrogate of mixture performance.

Other technologies for rapid testing were presented that may also be helpful if further developed. It is also probable that with rapidly advancing automation technologies in many fields of instrumentation that there are other ideas that may be adapted to testing of HMA. Other manufacturing industries should be formally scanned for such technologies.

Lastly, it is recommended that FHWA, AASHTO, NCAT, and the HMA industry jointly establish a national oversight group specific to real-time testing of HMA. This group should have formal responsibilities of reviewing new concepts, establishing priorities, setting guidelines for research and field trials, and general coordination of development and implementation activities pertaining to automated quality control and quality assurance testing.

## **REFERENCES**

1. Innovations Deserving Exploratory Analysis (IDEA) Program Announcement, Transportation Research Board, Washington, D.C., [www.national-academies.org/trb/idea](http://www.national-academies.org/trb/idea)



## Appendix A

### QC Automation Discussion Panel Roster

1. Randy Mountcastle, Alabama DOT
2. Tom Baker, Washington DOT
3. Judie Ryan, Wisconsin DOT
4. John Bukowski, FHWA
5. John D'Angelo, FHWA
6. Larry Michael, Maryland SHA
7. Guy Savage, East Alabama Paving
8. Jack Weigel, Payne & Dolan
9. Mark Harned, Astec Inc.
10. Greg Renegar, Astec, Inc.
11. Tom Copeland, Astec, inc.
12. Mark Calloway, J.B. Long, Co.
13. Jason Laffan, Hydronics
14. Mike Bienvenu, Troxler Electronics Laboratories
15. Craig Hitchcock, Analytical Process
16. Tod Canty, J.M Canty, Inc.
17. Kevin Singler, Rotex, Inc.
18. Ron Collins, PTI
19. Ken Cosby, Terex
20. David Breshears, Gencor
21. George White, University of Washington
22. Adrian Field, Stonemont Solutions
23. Ray Brown, NCAT
24. Joe Mahoney, University of Washington
25. Chuck Van Deusen, Consultant
26. Kent Hanson, NAPA
27. Randy West, NCAT

## **QC Automation Panel Meeting Agenda**

July 21-22, 2004  
National Center for Asphalt Technology

### **Tuesday, July 20:**

1:00 – 4:30 pm, QC Automation Open House, East Alabama Paving

### **Wednesday, July 21:**

8:00 – 10:30 am, QC Automation Open House, East Alabama Paving

12:00 noon – 5:00 pm, **QC Automation Panel Meeting** (invited attendees), NCAT

- 12:00 noon Lunch provided at NCAT
- 1:00 pm Objectives of the meeting Randy West
- 1:15 pm Presentations of current technologies (20 min each)
  - Binder Viscosity Craig Hitchcock
  - Belt Sampling Mark Calloway
  - Moisture Content Jason Laffan
  - Gradation
    - Sieve method Greg Renegar
    - Video method Todd Canty
  - Binder Content David Brashears
  - Mix Temperature Greg Renegar
  - Data Management George White
- 5:00 pm Adjourn for the day

### **Thursday, July 22: QC Automation Panel Meeting continued, NCAT**

- 8:00 am Technical hurdles Panel Discussion
  - What technologies are ready?
  - What needs to work better?
  - What information is missing?
- 9:15 am Break
- 9:30 am Economic hurdles Panel Discussion
  - cost/benefit
  - paying for the technology
  - competition of technology suppliers
- 10:15 am Social/political hurdles Panel Discussion
  - approval by agencies
  - acceptance by producers
- 10:45 am Planning the next step Panel Discussion
  - Marketing the idea
  - Research & development needs and funding
- 11:45 am Wrap Up Randy West
- 12:00 noon Adjourn

## **Appendix B**

### **Presentations of Automated Technologies from the QC Automation Panel Meeting**

## Online Viscosity of Asphalt

Craig Hitchcock  
Analytical Process Inc.  
Houston TX



## Definition of Viscosity

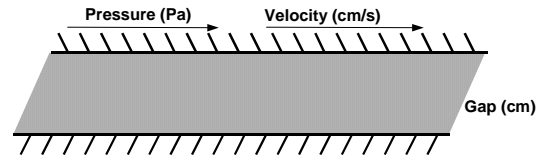

$\eta$  = viscosity (Pa · s)

$F$  = force (Pa)

$\gamma$  = shear rate

$$\text{shear rate: } \gamma = \frac{\text{velocity}}{\text{gap}} = \frac{\text{cm/s}}{\text{cm}} = \frac{1}{\text{s}}$$

$$\text{viscosity: } \eta = \frac{F}{\gamma} = \frac{\text{Pa}}{1/\text{s}} = \text{Pa} \cdot \text{s}$$



## Definition of Viscosity

- Types of geometries ASTM D4402-02

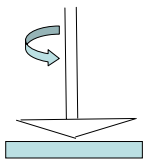

Cone and plate

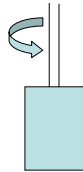

Concentric cylinder



## Definition of Viscosity

- Kinematic Viscosity ASTM D2170-01a

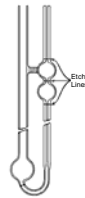

Viscosity is proportional to the drop time compared with a known viscosity. Since the driving force is gravity, the kinematic viscosity is viscosity/density. Units are in stokes



## Viscosity Relationships

1 PaS=1000mPaS=10Poise=1000centipoise  
1Stoke=1poise/density

Water = 0.1P

Oil=10P

Asphalt (at 275F) = 10P

Asphalt (at 75F) =1,000,000P



## Asphalt Viscosities

Sample of 2 separate grades at 135° C (275 ° F)

Roadway PG 67-22

.4 to .6 PaS

Highway PG 76-22

1.8 to 2.2 PaS

Significant viscosity difference



### Laboratory Tests

- Disadvantages
  - Labor intensive
  - Delay time in receiving results
- Advantages
  - ASTM Approved
  - Control of Rheological conditions (temperature and Shear)



### On Line Measurement

- Advantages
  - Instantaneous results to control room
  - Reduced Labor
  - Available automated control loops and safeties
- Disadvantages
  - Not ASTM approved
  - Does not have control of rheological conditions



### Theory of Operation of the Online Viscometer

The rod is held in vibration at a frequency of 300 Hz by the drive magnet.

The dampening of the Amplitude is detected by the sensor magnet and converted to a viscosity signal.

No wearing parts = Very rugged

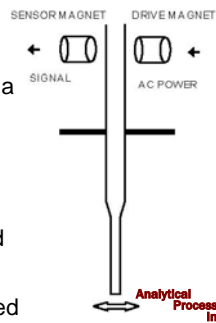

### Technical Drawing of Viscometer

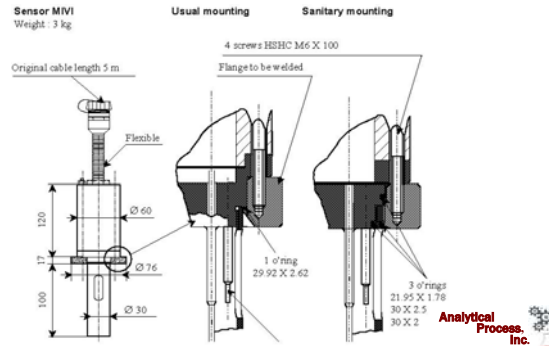

### Mounting of the On line Viscometer

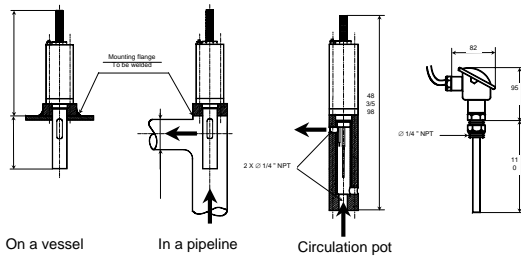

### Temperature Compensation

Mathematical Temperature compensation can be made to reduce the problem of process temperature variations.

Need to develop the table of viscosity vs. temperature and specify the reference temperature.

Temperature compensation is not recommended past 20F of the reference temperature.



### Advantages of Online Viscosity

- Prevent paving with wrong specification of asphalt
- Immediate and continuous results to control room
- Reduction of labor costs



### Advantages of Online Viscometer

- No wearing parts - Very rugged and reliable
- 0.2% of full scale Reproducibility, test unit is 5,000 cP (+/- 10cP)
- Operates continuously up to 392F (with option to 572F)
- Easy to clean and calibrate
- Has temperature compensation to reference temperature
- Relatively affordable (approx. \$18K)



# CLEAN SWEEP® Sampling Systems

*REFERENCE QUALITY SAMPLING*  
*National Center for Asphalt Training*

**JOHN B. LONG Co**  
<http://www.jblco.com>

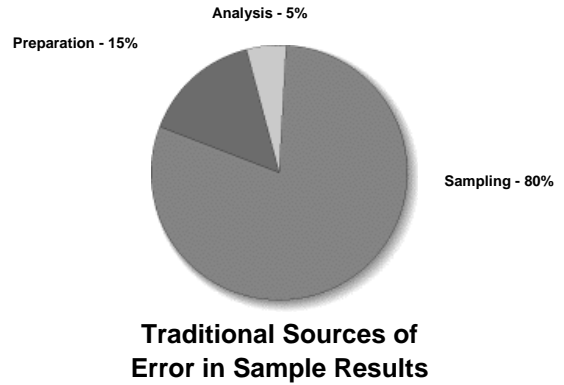

JBLCo

## KEY ELEMENTS OF SAMPLING

**Accuracy** - the ability to obtain sample increments that correctly portray the true nature of the material being sampled.

**Precision** - a measure of the variability of the sample to the material being sampled.

JBLCo



**Reference Method**  
**Complete Cross-Section Removal**  
**by Stopped-Belt Sampling**

JBLCo

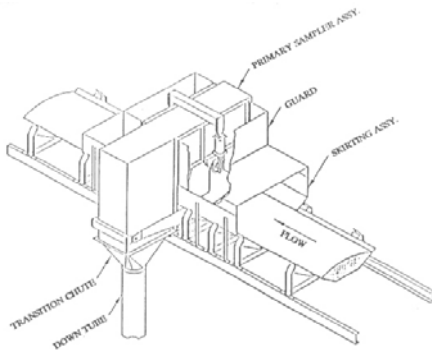

**Sweep (Cross-Belt) Sampler**

JBLCo



**CLEAN SWEEP® Sampler Retro-fit**  
**Installation on a Truck Load-out Conveyor**

JBLCo



**QC-360 Retro-fit Application  
Feeding a Vision Analyzer**

## **New QC-360**

- Quality Control Sampler
- Low Cost/Low Maintenance
- Electric Drive
- Central Lubrication
- Easily Removed and Installed



## **CHALLENGES TO SWEEP SAMPLER AUTOMATION**

1. Multiple Products Per Belt

JBLCo



**PLC CONTROLLED CAROUSEL**

JBLCo

## **CHALLENGES TO SWEEP SAMPLER AUTOMATON**

1. MULTIPLE PRODUCTS PER BELT
2. PLC PROGRAMMING/ THE HUMAN FACTOR

JBLCo



**QC-360™ Series Sampler With Available PLC**

JBLCo



## QC-360 Controls

- Manual or Push Button Controls
- Can Be Wired to Operate With Plant PLC
- Optional PLC Available
- Mass Based Weighing Option
- Available Ticket Printers



**Available Control Options**  
**Integrated Motor & PLC Control Panel With**  
**Face Mounted Operator Control & System**  
**Status Display, Available Data Collection.**

JBLCo



Controlled by Plant PLC

JBLCo

## Mass Based Weighing and Sampling



Utilize a new or existing belt scale to send a cut signal at pre-programmed intervals. Build accurate and precise stock piles. Real time information before contamination.

## JOHN B. LONG Co

- Established in Knoxville, Tennessee 1984
- Manufacturer of CLEAN SWEEP® sampling systems
- 24 Patents worldwide / additional pending
- Over 700 systems in service sampling 13 different bulk materials in 13 countries
- System installations to
  - 96" Belt Width
  - 11,000 TPH
  - 1100 fpm

## CLEAN SWEEP® Sampling Systems

And Now  
The QC-360

JOHN B. LONG Co  
<http://www.jblco.com>

## Moisture Measurement and Control for the Asphalt Industry



## Introduction and Topics For Discussion

- Introduction and topics for discussion
- Benefits of moisture measurement
- Criteria for effective moisture control
- Available technologies, techniques and products
- On-line moisture measurement in aggregates
- Criteria recap and conclusion

## Benefits of Moisture Measurement

Control – Quality – Cost – Efficiency - Simplicity

- Energy efficiency, controlling the burners
- Product consistency
- Comparative energy performance measurement across plants
- Completely automatic from start-up
- The Owner – What can we save ?
- The Plant Supplier – How can we simplify our plant, how can we create or add value ?

What are we trying to achieve ?

## Criteria for Moisture Measurement

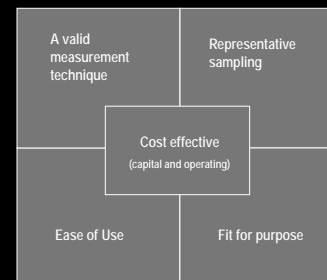

## Nuclear Technique

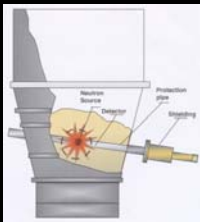

Berthold Industrial Systems

### For

- Accuracy
- Temperature, pressure, pH value and particle size do not effect measurement
- Non-contact measurement

### Against

- Very expensive \$10,000 upwards
- Large field of measurement, more appropriate for slow moving high volume material
- Measurement in bins may not be representative of the material being used
- Safety and handling requirements

## Infra-red



Infra-Red Systems

### For

- Non-contact measurement
- Accurate if correctly configured

### Against

- Surface measurement
- Effected by changes in colour
- Effected by changes in temperature
- Requires frequent calibration
- Vulnerable to dirt / dust and condensation on the lenses

## Resistance Based Meters

### For

- Inexpensive
- Contact measurement technique
- Representative sampling



Biotronic GmbH

### Against

- False readings
- Water in its pure state is a non-conductor
- Measures impurities in water
- Effected by minerals / salts
- Effects of temperature 1% for every 1.8degF
- Drying and re-wetting of aggregate can cause reading fluctuations
- Different pH values of the material may effect the readings
- Working Range 0-5% or 0-10% in freshly washed aggregates

## Capacitive Technique

### For

- More advanced than Resistive
- Inexpensive
- Contact measurement technique
- Representative sampling
- Penetration of around 10cm into material

### Against

- Not a water specific measurement
- The dielectric measurement can be influenced by free ions (salts)
- Density dependant (aggregate size and distribution)
- Working range 0-10%



ACO Automation, High Frequency Capacitance

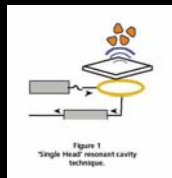

Figure 1  
"Single Head" resonant cavity technique.

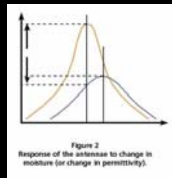

Figure 2  
Response of the admittance to change in moisture (or change in permittivity).

## Microwave Technique

### Operating Principles

- Absorption of microwave energy by water is 100 times greater than for most dry materials
- Measuring the energy absorbed provides an accurate measurement of the moisture present in the material
- This technique uses very little power (milliwatts) hence, no heating effect and perfectly safe.

## Microwave Technique

### For

- High sensitivity to water
- Good penetration of measurement, representative sampling
- Not significantly affected by impurities such as salts
- Not affected by temperature (0-50°C)
- Not affected by colour
- Not significantly affected by particle size
- Economical - Costs between \$3,000.00 to \$5,000.00 per line

### Against

- Density dependant



www.hydronix.com

10

## Microwave Technique

### Practical to Use

- Versatile in use - may be fitted in many different ways to suit application
- Easy to install
- Easy to remove and check if OK
- Robust and reliable
- Perfectly safe



www.hydronix.com

11

## Microwave Technique

### Limits of Measurement

- Fine sand.....16-25%
- Coarse sand.....10-12%
- 6mm (1/4in) Aggregate ..... 8-10%
- 10mm (3/8in) Aggregate..... 6-8%
- 20mm (3/4in) Aggregate ..... 3-4%
- Lightweight Aggregate ..... 20-60%
- Fresh Concrete .....12-15%



www.hydronix.com

12

## Microwave Technique

### Overall System Accuracy



- Accuracy of measurement under 'controlled' conditions  $\pm 0.1\%$
- System accuracy in practice, depends on:
  - sampling of material being measured / calibration
  - accuracy of laboratory tests and sampling techniques used for comparing results
- In practice, measuring in aggregate we say  $\pm 0.2\%$



13

## Microwave Technique

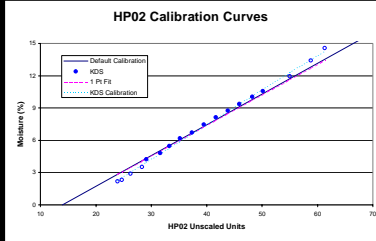

### Overall System Accuracy

14



## The Hydro-Probe II

- The Flagship of Hydronix
- Over 25,000 units sold in over 45 Countries
- Linear output
- Digital Sensor, each one is the same
- RS232/485 output
- Integrate directly to control system
- Daisy chain up to 16 on an RS485 network

15

## The Hydro-Probe II

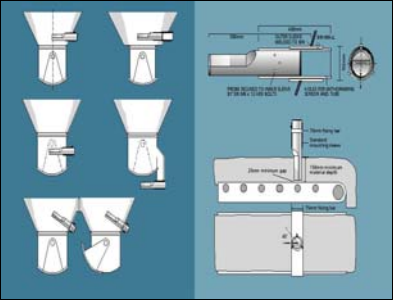
16

## Asphalt Application Issues

- Where to measure
- Representative sample
- High number of aggregates
- Consistent flow characteristics, (speed, depth)
- Consistent material properties (calibration / recipes)



17

## Hydro-Probe II Aggregate Bin Installations



CONCRETE - VARIOUS WORLDWIDE



18

### Hydro-Probe II Asphalt Conveyor Installation

Hydronix  
www.hydronix.com

ASPHALT - HOLLAND

19

### Hydro-Probe II Possible Asphalt Conveyor / Freefall Installation

Hydronix  
www.hydronix.com

ASPHALT - FRANCE

20

### Criteria for Moisture Measurement

- Infra-Red
- Capacitive
- Resistive
- Microwave
- Nuclear

A valid measurement technique	Representative sampling
Cost effective (capital and operating)	
Ease of Use	Fit for purpose

Hydronix  
www.hydronix.com

21

### Criteria for Moisture Measurement

- Infra-Red
- Capacitive
- Resistive
- Microwave
- Nuclear

A valid measurement technique	Representative sampling
Cost effective (capital and operating)	
Ease of Use	Fit for purpose

Hydronix  
www.hydronix.com

22

### Criteria for Moisture Measurement

- Infra-Red
- Capacitive
- Resistive
- Microwave
- Nuclear

A valid measurement technique	Representative sampling
Cost effective (capital and operating)	
Ease of Use	Fit for purpose

Hydronix  
www.hydronix.com

23

### Criteria for Moisture Measurement

- Infra-Red
- Capacitive
- Resistive
- Microwave
- Nuclear

A valid measurement technique	Representative sampling
Cost effective (capital and operating)	
Ease of Use	Fit for purpose

Hydronix  
www.hydronix.com

24

## Criteria for Moisture Measurement

Infra-Red  
Capacitive  
Resistive  
Microwave  
Nuclear

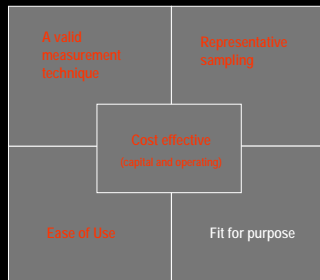

  
Hydronix  
www.hydronix.com

25

## Criteria for Moisture Measurement

Infra-Red  
Capacitive  
Resistive  
Microwave  
Nuclear



  
Hydronix  
www.hydronix.com

26

*~ Thank you ~*

  
Hydronix  
www.hydronix.com

27

## Automatic Gradation Unit

NCAT 2004



What is being measured ?

Why is this important ?

### How does it work ?

- Belt sweep obtains sample.
- Sample is dried and moisture is calculated.
- Aggregate is separated.
- Screen assembly rotates 90 degrees.
- Doors open one at a time allowing the aggregate on each sieve to be weighed.
- Gradation is calculated and displayed.







## Calibration

- The scale is calibrated by adding known weights.

## Display

- Local
- Remote

## Limitations

- RAP is too sticky to screen at plant.
- Sample is not washed.

## Cost

- Belt sweep – 24” \$14,470  
30” \$15,580
- Aggregate dryer - \$21,580
- AGU – 40lb field \$48,960







*J. M. Canty Inc*  
*Tod Canty*

Buffalo, New York  
Dublin, Ireland  
www.jmcanty.com



### *Imaging Based Size and Shape*

- ◆ .7 Micron to 8in rock
- ◆ Liquid Slurry (drilling mud)
- ◆ Dry or wet solids
- ◆ Not affected by moisture
- ◆ Measure size and shape...super pave
- ◆ Lab and Online identical...matches screen



### *Ehernet Based*

- ◆ Image transmitted via ethernet camera
- ◆ Wired or wireless
- ◆ Networked
- ◆ Remote access Windows XP



### *Lab and On-line Systems for Sizing Aggregates*



### *Agenda*

- ◆ Introduction
- ◆ Sizing Applications
- ◆ Belt Volume Measurement
- ◆ Concepts of Image Processing
- ◆ Equipment
- ◆ Real Time Measurement
- ◆ Output Data / Process Control
- ◆ Visual Verification
- ◆ Demonstration
- ◆ Payback
- ◆ Conclusion
- ◆ Questions & Answers

### *Introduction*



Vision Based Approach for Sizing  
Aggregates From Micron Size  
Material With No Upper Size Limit

Correlates To Sieve  
Analysis!!!!!!!!!!!!

## Sizing Applications for Aggregates in the Lab and On-line

- ◆ Classifiers
- ◆ Screen Decks (Screen Break and Screen Blinding)
- ◆ Crushers (Setup)
- ◆ Wash Plants

## Belt Volume Measurement

VOLUME FLOW CONTROL

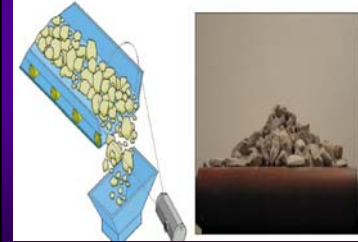

- ◆ Measures True Volume Using 2D Image and Belt Speed.
- ◆ Accuracy +/- 1%
- ◆ No Maintenance
- ◆ Non-Contact
- ◆ Visual Verification

## How Does it Work?

Canty uses CCD cameras with patented lighting systems and image processors to analyze the material. The results are a true 3 dimensional size and shape analysis in real time. The video signal is sent at 30 frames per second and analyzed. Results can be reported in a tabular form to correlate to a sieve analysis or can be sent as an output signal such as a 4-20mA current loop for process control. All files are able to be archived for a historical record.

## How is it used?

It can be used in the lab to eliminate the lengthy sieve analysis. Results are outputted in seconds. From the lab it can be implemented in the field with automatic sampling devices like belt sweeps, head pulley samplers, etc... Output signals can then be used for process control and to alert operators of out of spec material.

## Typical On-line Installation

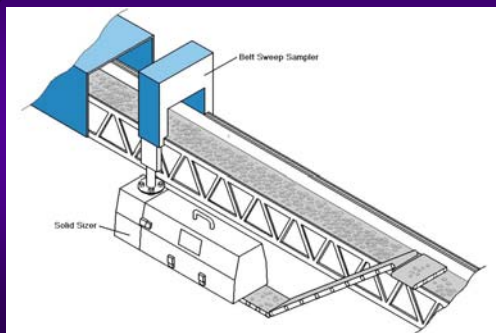

## Concepts of Image Processing

- ◆ Human Eye
- ◆ Lighting (Key Component)
- ◆ Digitizing Image
- ◆ Image Filters
- ◆ 3D True Size and Shape Analysis
- ◆ Output Signal / Data Storage



## Processing Steps

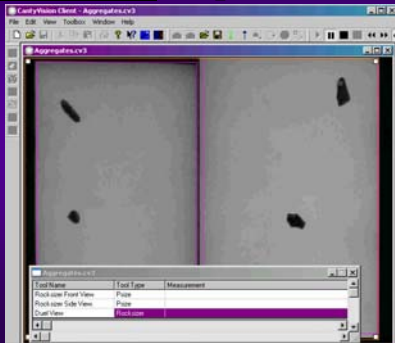

## Equipment

- ◆ Light Source
- ◆ CCD Camera
- ◆ Spray Ring
- ◆ Image Processor
- ◆ Analyzer



## Light Source



- ◆ Fiber Optic Lighting to illuminate material for true size and shape
- ◆ Weather Proof
- ◆ Regulated PSU
- ◆ Fused Glass (Standard)
- ◆ 40 through 250 Watts



## CCD Camera



- ◆ Color or Black & White
- ◆ Fused Glass (Standard)
- ◆ Weather Proof
- ◆ Macro Lens Option
- ◆ Spray Ring Option
- ◆ Cooling Tube Option
- ◆ NO Maintenance!



## Spray Ring



Designed to keep product and debris from building up on the fused glass front cap of the camera system ensuring a clear view at all times. Air or any fluid compatible with the materials can be used.



## Image Processor



- ◆ Windows™
- ◆ Industrial Chassis
- ◆ Multiple Inputs
- ◆ Multiple Outputs
- ◆ Standard 4-20mA
- ◆ Excel Interface
- ◆ Ethernet Connection
- ◆ Modem (Support)



## On-line Solid Sizer



- ◆ Lab or On-Line
- ◆ Stainless Steel Construction
- ◆ Weather Proof
- ◆ 20 through 6000 microns
- ◆ Various Lighting Options
- ◆ Various Inlet / Outlet Ports



## Rock Sizer



- ◆ Lab or On-Line
- ◆ Weather Proof
- ◆ .1" through 2" Standard
- ◆ Other Size Range Options
- ◆ Fiber Optic Back Lighting
- ◆ Fused Glass (Standard)
- ◆ Rugged Construction



## On-Line Measurement

- ◆ Lab Samples
- ◆ Production Stream
- ◆ Repeatable / Accurate
- ◆ Response Time
- ◆ Archived Data



## Output Data / Process Control

- ◆ Displays
  - ◆ Reports
  - ◆ Tables
  - ◆ Graphs
- ◆ Output Signals
  - ◆ 4-20mA
  - ◆ Digital
- ◆ Process Control



## Visual Verification

- ◆ Key Advantage
  - ◆ Operators View Process in Real Time
  - ◆ Grid Overlay
- ◆ R&D
  - ◆ Recording Files
  - ◆ Images



## Particle Sizing Demonstration



## **Belt Volume Demonstration**



## **What is the Payback?**

Payback is determined by several factors. First is the labor reduction. More samples can be run in less time. Second, is the lag time for results is significantly reduced so if out of spec material is being produced it can be identified immediately before it contaminates stock and has to be reworked. There is no more out of spec stock piles or rejected loads from customers and state inspectors.



## **Conclusion**

- ◆ Real Time Measurement
- ◆ Repeatable / Accurate
- ◆ 3D True Size and Shape
- ◆ Visual Verification
- ◆ Output Signals
- ◆ Process Control
- ◆ Better Quality
- ◆ Higher Yield



## **Questions & Answers**

# ASPHALT CONTENT

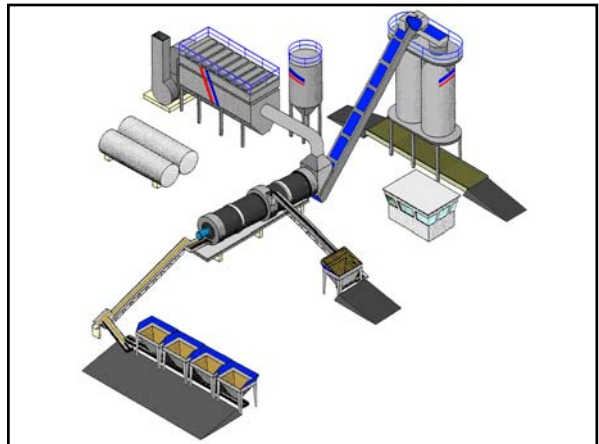
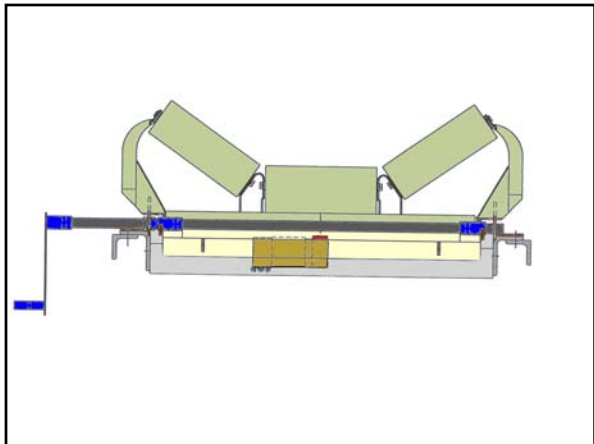
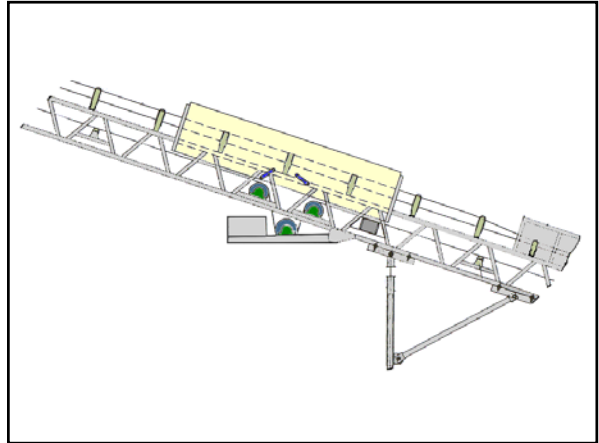
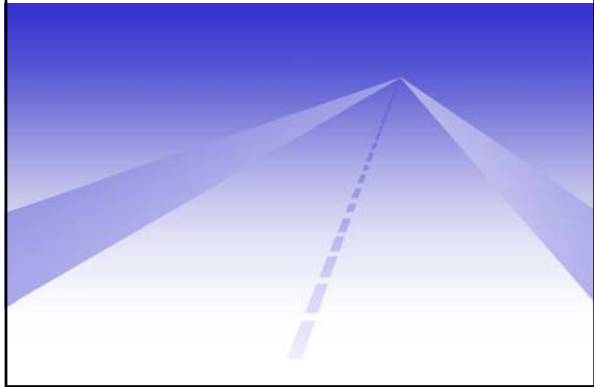



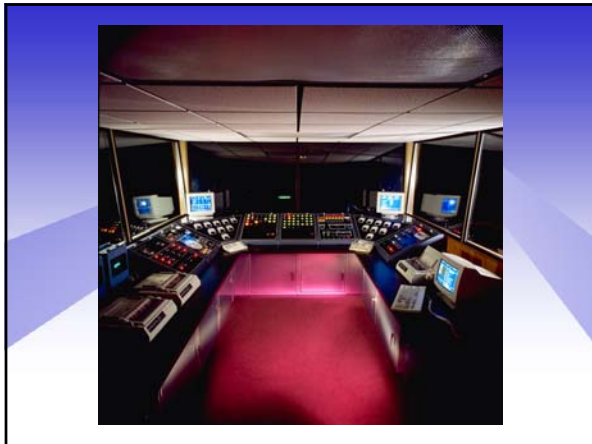

## ASPHALT CONTENT



CONTROL ERROR  
TESTING ERROR

## CONTROL ERROR



VARIABLE MEASUREMENT ERROR  
TIMING ERROR  
CALIBRATION ERROR  
CONTROL RESPONSE ERROR

## VARIABLE MEASUREMENT



- Aggregate mass flow rate
- AC Mass flow rate
- Moisture %
- Production rate
- AC temperature
- RAP %
- RAP % AC content
- Dust removal mass flow

## TIMING



- Aggregate transit time
- Dust return transit time
- Baghouse cleaning cycle
- Dust surges
- Aggregate surges
- AC transit time
- Load swings

## CALIBRATION



- Asphalt
- Aggregates
- Dust scales
- RAP characterization

# CONTROL RESPONSE



Actuator speed  
PID/ slew rates  
Meter response

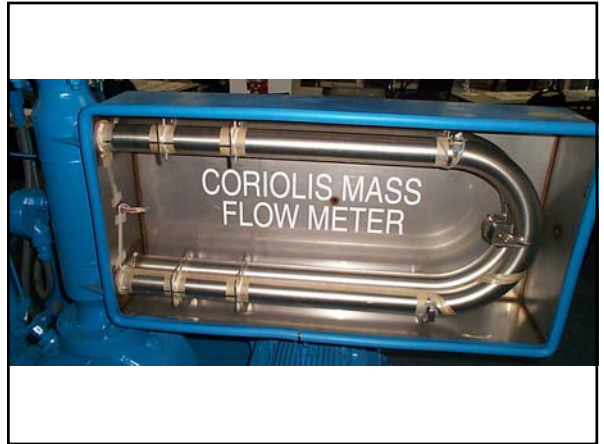
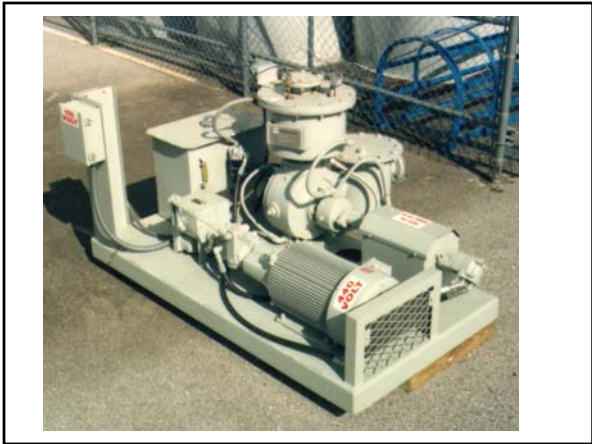
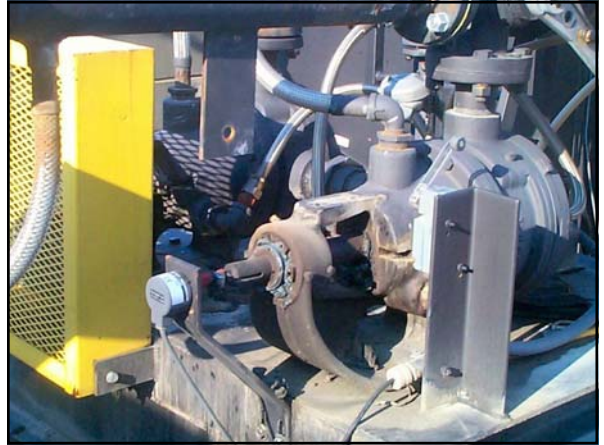
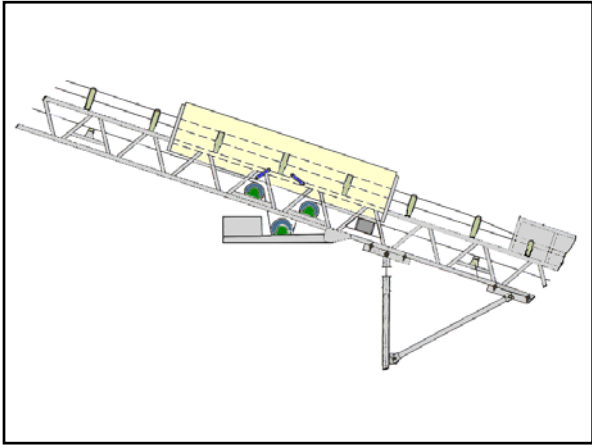
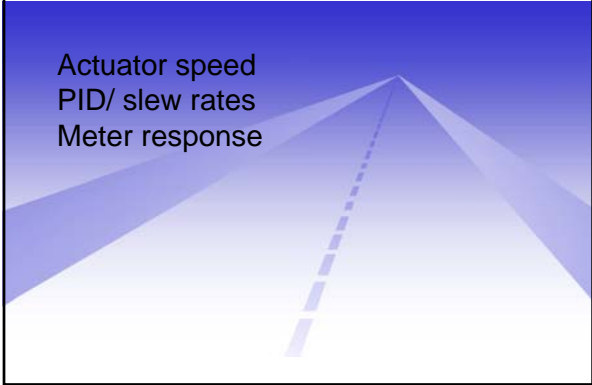

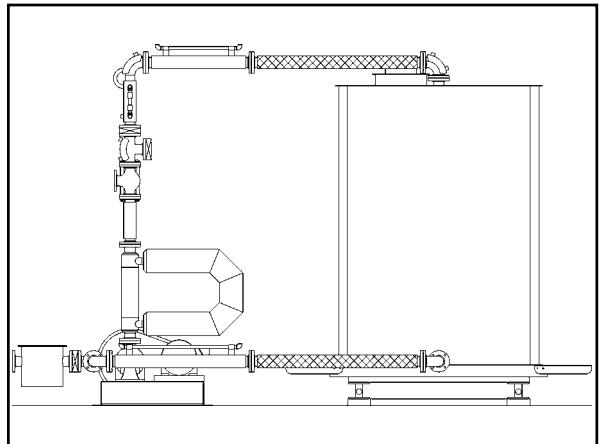
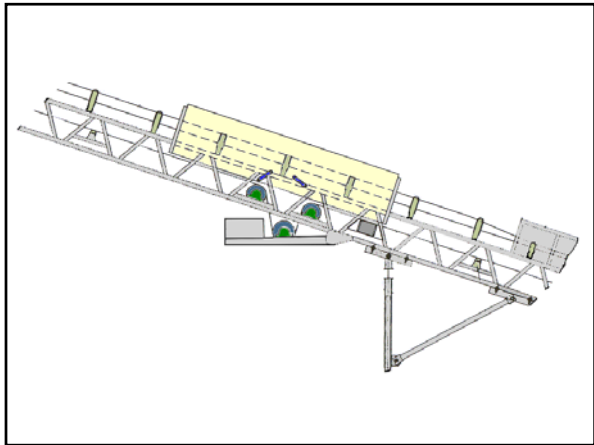

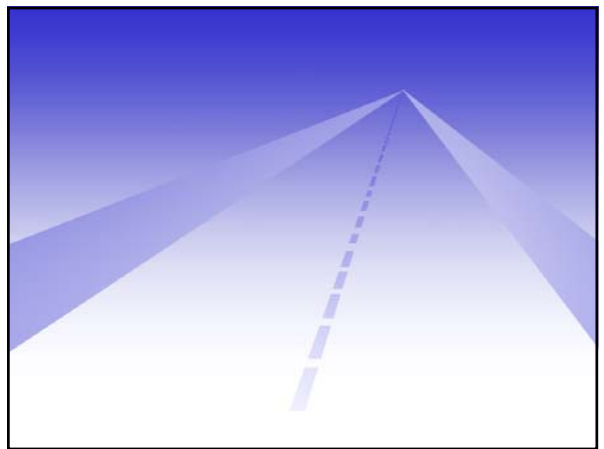

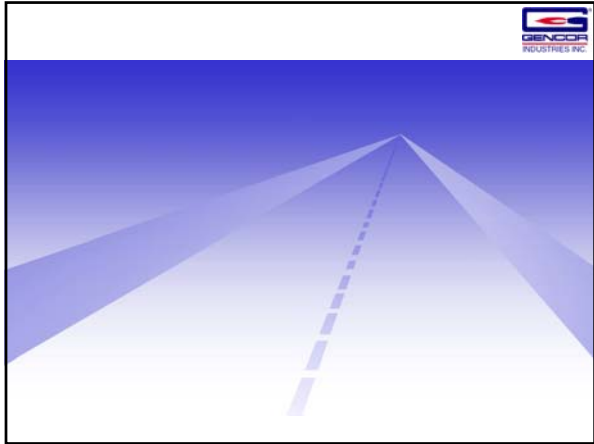

# Temperature Measurement

NCAT Meeting 2004

## What is being measured ?

- Aggregate for burner control
- Hot mix at mixer exit
- Drum gas temperature

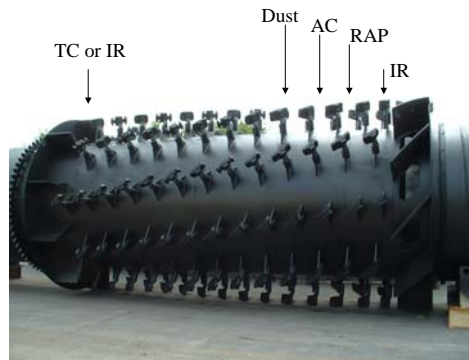
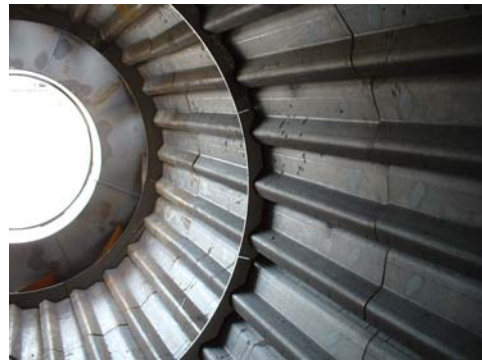

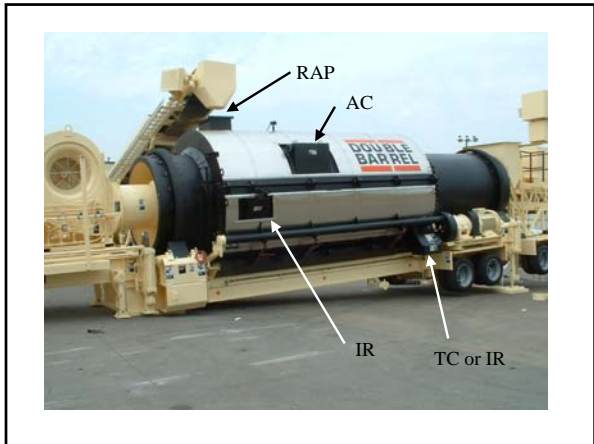

## Thermocouple

- How it works
- Calibration





## Thermocouple Pros-Cons

- Industry standard
- Rugged
- Easy to troubleshoot
- Inexpensive
- Contact sensitive
- Build-up sensitive
- Wear
- Slow response



## Infrared

- How it works
- Calibration



## Infrared Pros-Cons

- Fast response
- No contact with mix
- Low maintenance cost
- Expensive
- Requires purge air
- Delicate lens
- Cannot see through dust or steam
- Difficult to troubleshoot
- Focal length sensitive





## Temperature Output

- Process controller
- Chart recorder
- Plant computer

Questions ?

# QC Automation: Data Management

George White, University of Washington

## Agenda

- What is Data Management?
- HMA Data Management
- Data Flow
- Current Technology
- Considerations
- Summary
- Questions

## What is Data Management?

- Refers to all levels of managing data from computer storage and retrieval, software, standards, data administration, and organizational functions.
- Planning, development, implementation, and administration of systems for the acquisition, storage, and retrieval of data.
- Not necessarily generation and use of data

## Hot Mix Data Management

- Refers to management of data that is related to and collected during the entire paving process

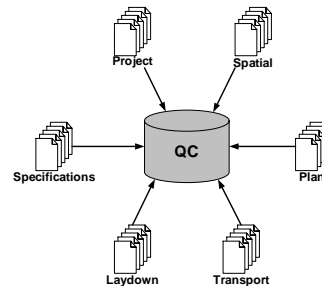

## Hot Mix Data Today

- HMA industry is currently generating and collecting a lot of data
- Most data is collected into disparate data stores or proprietary systems making integration and post-process evaluation difficult
- What data is collected is often under utilized and difficult to access and/or distribute

## Hot Mix QC Data Today

- Data is collected in several modes
  - Plant process control
  - Lab testing
  - In place and field collection
- Poor data relationships between modes
- Effect of good or bad quality control sometimes cannot be determined for years
- Not providing timely distribution of data and information to key personnel

## Hot Mix QC Data Processes

- **Aggregate, Binder**
  - Construction of component materials
- **Plant production**
  - Data produced at the plant for monitoring specific plant processes, etc.
- **Construction**
  - Transport, lay down, compaction and other paving site operations (mat characteristics, temperatures, compaction data)

## Hot Mix QC Data Flow

- **Collection**
- **Input**
- **Validation**
- **Pre Processing**
- **Storage & Archival**
- **Post Processing**
- **Presentation**



## Hot Mix QC Data Flow

- **Collection**
- **Input**
- **Validation**
- **Pre Processing**
- **Storage & Archival**
- **Post Processing**
- **Presentation**

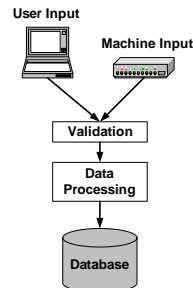

## Hot Mix QC Data Flow

- **Collection**
- **Input**
- **Validation**
- **Pre Processing**
- **Storage & Archival**
- **Post Processing**
- **Presentation**

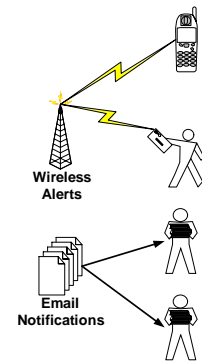

## Hot Mix QC Data Flow

- **Collection**
- **Input**
- **Validation**
- **Pre Processing**
- **Storage & Archival**
- **Post Processing**
- **Presentation**



## Current Hot Mix Software

- **Proprietary Systems**
  - Highly specialized and tailored to company
  - Require in-house support and maintenance
  - Modifications are costly, not very reusable
  - Typically last several years before rebuild
- **Examples Include:**
  - QCIS (Granite Inc.) – System developed to integrate all of their labs and facilities and to share data.

## Current Hot Mix Software

- Existing Off-shelf Systems
  - Systems are still specialized, but more modular
  - Maintained by consultants and/or software companies
- Examples Include:
  - Total Control 2000 (ASTECC Inc.) - Modular control system for process control in plant
  - aggQC 3.0 (Stonecount Solutions) – Aggregate testing and tracking software.
  - QMS (Atser Inc.) – Quality Management System developed by consultant group

## Current Hot Mix Software

- Data & Content Management Systems
  - Provides data through modular web portals
  - Requires data management strategy
  - Inherent security and highly available datasets
- Examples Include:
  - HMAView (UW) – A web-based HMA data portal used by WSDOT and MDSHA (more coming)
  - WebSphere (IBM) – Enterprise level, industry proven web content management system
  - Lots of others...

## QC Automation Data

- Provide easy access to data from many collections and sources in one easy to use interface
- Notifications and updates when something changes
- Confidence in consistent data and security
- Ability to analyze and examine data across datasets

## QC Data Management Costs

- The cost of creating a custom data management system can be quite high
- Once created, the system will require continued maintenance and support
- Individual agencies and contractors have spent millions to try to solve individually
- Costs can be reduced by creating an open data environment and utilizing 3<sup>rd</sup> party applications and tools

## Current HMA QC Limitations

- Too many proprietary data formats and systems to get meaningful datasets
- Still not providing data to key personnel in a timely fashion
- Too much “hands on” data collection and dissemination
- Not relating plant data to actual mat placement and roadway performance
- We’re not using the data to its full potential

## Considerations

- Data half-life
  - How long is the data useful?
- Data domains
  - What groups/personnel are interested in using data?
- Data sharing
  - Providing mechanisms to effectively distribute data
- GIS Integration
  - Providing location and time for data

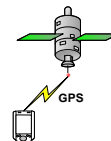

## Integrate with other datasets

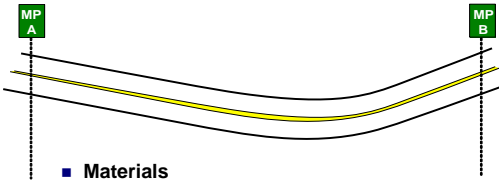

- Materials
- Construction quality
- Traffic
- Surface condition / performance
- Rehabilitation / maintenance
- Digital media
- Etc. etc. etc.

## Recommendations

- Determine a data management strategy by outlining specific end-user needs
- Determine data “half-life” and outline specific goals with respect to data
- Integration with other data
- Consider standards for communicating data among applications and devices
- Utilize technology currently available to provide integration and presentation

## Wrap Up

- In order to make full use of automated equipment timely data processing is required
- While automated collection techniques are improving, presentation and dissemination of data can be significantly improved
- Data management and presentation is perhaps the most critical component to QC automation and HMA monitoring

## Questions?



George White  
gcw@u.washington.edu

## Automated QC & Real-Time Testing

Utilization of Automation and Real-Time Testing to Improve QC/QA Procedures For Hot Mix Asphalt



## QC/QA State of Practice

- Most QC/QA specifications for HMA have become quite complex
  - Every subplot of mix, 5 to 6 physical tests are used to calculate a dozen or so characteristics for control criteria and pay factors.
- Technicians are overloaded and it's getting worse
- Time demand of management to address problems



## Is there a better way?

- What do we need to measure?
- Can we automate those measurements (remove the human element)?
  - minimize sampling & testing errors
  - increase frequency of measurements
  - provide rapid feedback (data acquisition and output) of the process
- How often does the data need to be validated?



## Proposed Automated QC Methods

1. Belt Sampling
2. Moisture Content
3. Gradation
4. Binder Viscosity
5. Binder Flow Meter
6. HMA Temperature

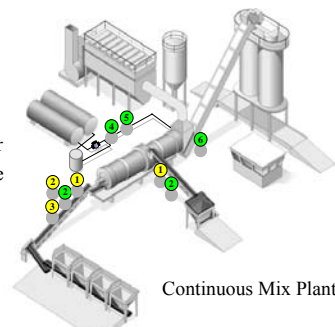

## Study Objectives

- Set up and evaluate the equipment and data collection
- Compare data to standard QC sampling & testing
- Evaluate feasibility of systems
- Determine best place to sample HMA for verification tests
- Host Open House / Demo Project



## Automated Asphalt Content Using a Plant's Controls



We already measure binder flow rate (gal./min. → tons/hr) with a flow meter or non powered positive displacement pump.



And we measure feed rates of aggregates and RAP (tons/hr) with belt scales, tachometers and a computer integrator



## Belt Scale Calibration



- Proper calibration of belt scales using material over the weigh bridge and diverted to a tared truck.
- Need better training on this.



## Moisture Content Gage

- Measures moisture content of aggregate on belt or in a bin.
- Requires calibration for each different material.
- Data is used to adjust weight reading of the belt scale.
- ~ \$4000 per probe



## Automated Moisture Contents

- Knowing the moisture content of the materials is also critical to understanding if the drying process is operating efficiently.
- And it may be an indicator that the loader operator needs training.



## Asphalt Meter Calibration



- Calibration Tank used to calibrate and check the asphalt meter
- Hands-free, therefore safer, faster, and more accurate
- ~ \$20,000

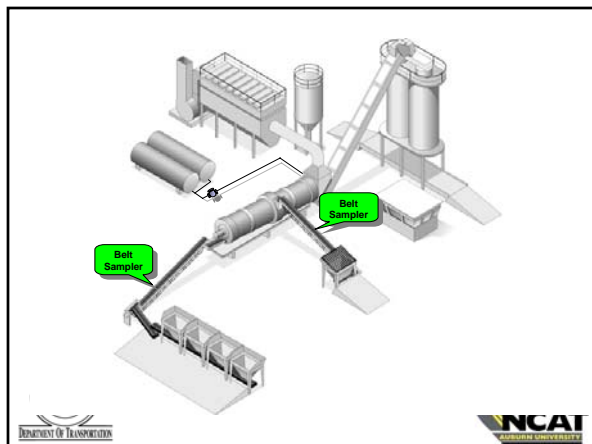

## Belt Sampling Device



- a.k.a. – belt sweeper
- Removes a sample of aggregate while the plant is running.
- Plan to have a belt sampler on the aggregate incline conveyor and the RAP conveyor
- ~ \$15,000



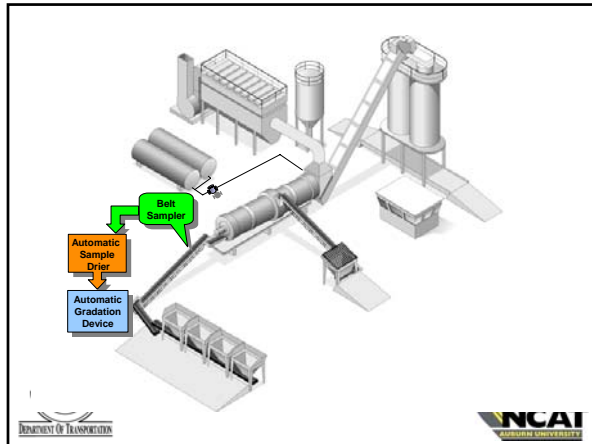

## Aggregate Sample Drier



- Receives aggregate or RAP sample from belt sampler and dries it before the automated gradation device.
- ~\$14,000



## Automatic Gradation Unit

- Sieves and weighs aggregate to produce a gradation.
- Data sent to PC in control house or lab
- ~\$38,000

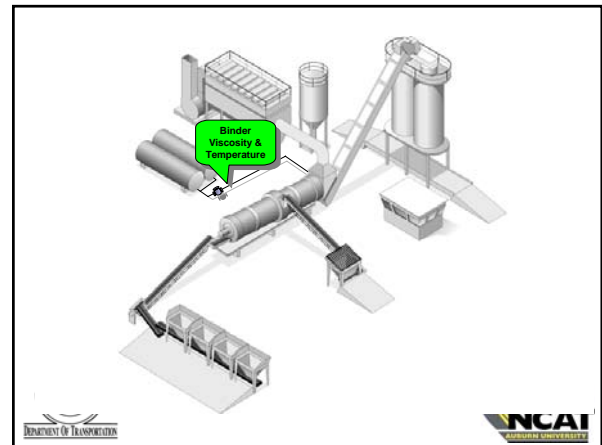

## In-Line Viscometer & Temperature System

- Measures the viscosity & temperature of the binder.
- Mounts in line from AC tank to injection point.
- ~\$23,000

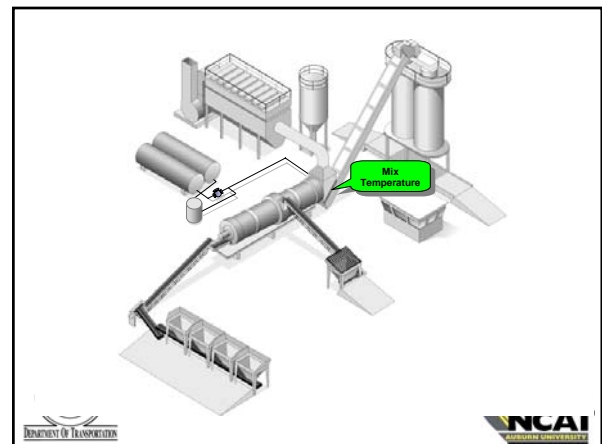



## Mix Temperature Gauge

- Mix temperature is often monitored by the plant operator, usually at the point of discharge from the mixer.
- Analog chart recorder is common, but we want a digital record.

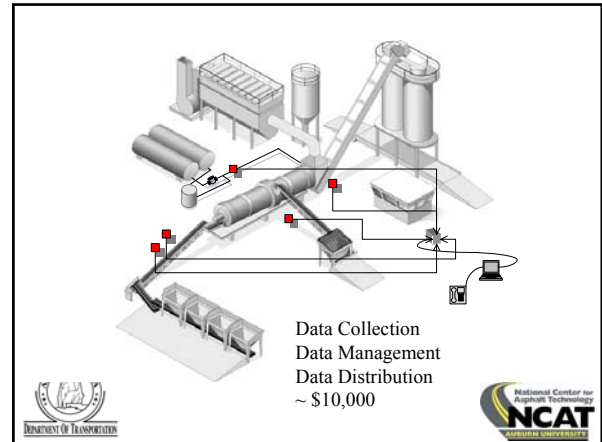

## Robotic Truck Sampler

- Obtains a large sample of HMA from a truck load of HMA.
- Safer because the technician does not have to get in the truck bed.
- Samples should be more representative of the load – avoid sampling of segregated material



## How about acceptance?

- Will agencies accept the automated data for determining pay of HMA?
- When and where should agencies take samples to verify quality?



## Project Summary

- Equipment & installation – \$236,000
- Compare standard methods of QC to the automated QC data for rest of this paving season.
- Determine if samples taken at the paving site or after construction can be used to validate mix quality.

